



WWW.BARRYIND.COM

RZC2010CT-50R0JN-2T



Aluminum Nitride

POWER CHIP RESISTOR

Features:

- ◆ Aluminum Nitride Material
- ◆ DC - 2 GHz Performance
- ◆ 30 Watt Input Power
- ◆ CT = Matte Tin over Nickel over Silver
- ◆ Surface Mountable

General Description:

The RZC2010CT-50R0JN-2T is a 50 ohm Aluminum Nitride power chip resistor. It has an input rating of 30 watts, while maintaining a constant mounting surface temperature of 100°C. It offers a frequency range from DC to 2 GHz.

Storage conditions: Parts should be left in supplied packaging and kept in a dry nitrogen cover gas to prevent oxidation.

Warranty: 1 year from shipment date; Storage as specified.

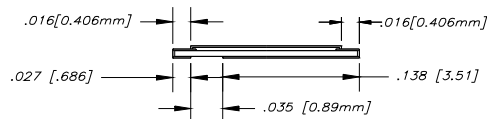
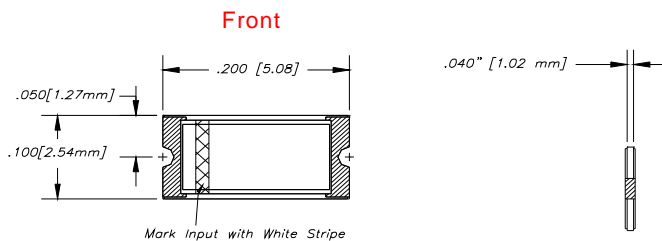
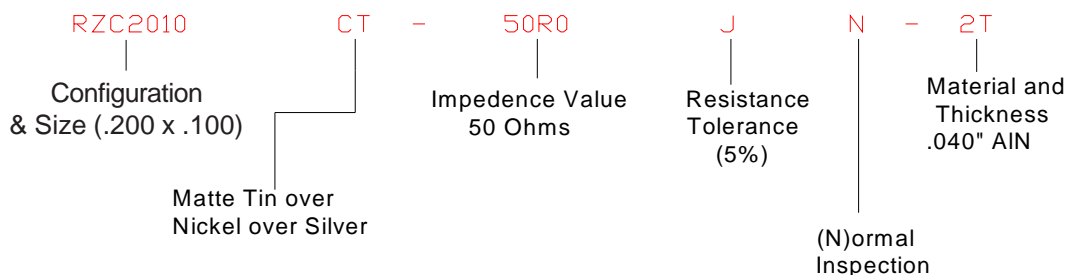
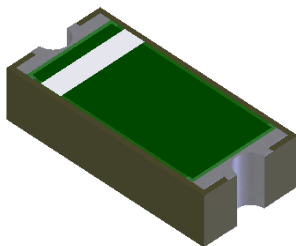

Dimensions in inches [mm]
 Tolerance ± .005 [.127]
 unless otherwise stated

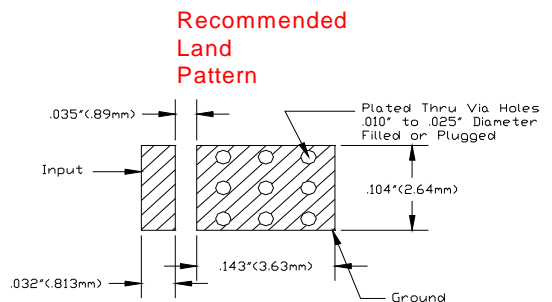

Barry Industries reserves the right to change part number and or process without notification.

Barry Industries, Inc., 60 Walton St., Attleboro, MA 02703 T: 508-226-3350 F: 508-226-3317 E-mail: ABSales@Vishay.com

Barry Industries maintains an ISO 9001 Certified Quality Management System

Origination Date	Revision Date	Rev.
06/07/10	06/07/10	-

Page 1 of 3

Electrical

Parameter	Min.	Typ.	Max.	Units
Frequency Range	DC		2	GHz
Input Return Loss	17			dB (VSWR)
DC Resistance	47.5	50	52.5	Ohms
Input Power			30	Watts

Temperature

Parameter	Min.	Max.	Units
Mounting Surface Temperature		100	°C
Operating Temperature Range	-55	150	°C

DERATING CURVE:

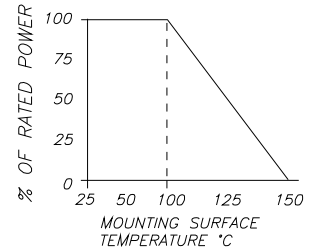

Reliability

Parameter	Test Conditions	Results
Short Time Overload	Apply 1.1 x rated power for 5 Sec.	± 5.0 % Resistance Shift
Rated Load Life	Apply half power under 40°C ± 2°C 90 minutes on / 30 minutes off, Repeat for 100 hours	± 5.0 % Resistance Shift
Moisture Load Life	Apply half power under 60°C ± 2°C 90 - 95 % RH 90 minutes on / 30 minutes off, Repeat for 1000 hours	± 5.0 % Resistance Shift
Solder Resistance	Dip into 235°C ± 5°C solder bath for 3 ± 0.5 second	± 5.0 % Resistance Shift
Terminal Strength	Lead pull 1 lb. for 5 Sec.	No Significant Abnormality (Visual)
Solderability	Dip into 235°C ± 5°C for 3 ± 0.5 seconds	>95% covered
High Temperature Storage	1.) 125°C ± 2°C 2.) 500 Hours	1.) Resistance shift ±5.0% 2.) No Significant Abnormality (Visual)
Thermal Shock	1.) -5°C to +150°C 2.) Each cycle 30 minutes for 5 cycles	1.) Resistance shift ±5.0% 2.) No Significant Abnormality (Visual)

Special Handling: Use this component under surface temperature of 250°C on resistance film.

Outgoing Inspection:

- 1.) Electrical Characteristics
 - a.) DC Resistance (constant current measurement) verify value and tolerance per Electrical table above
100% inprocess / sample per Inspection Standard at outgoing
 - b.) TCR (Temperature Coefficient of Resistance) One sample per manufacturing lot
 - c.) VSWR sample 4 pieces per manufacturing lot (when specified in product specification)
- 2.) Visual Characteristics
 - a.) Damage/Workmanship - Sample per Inspection Standard
 - b.) Contamination - Sample per Inspection Standard
 - c.) Dimensions - Sample per Inspection Standard, verify tolerance within limits as specified on page 1

Packaging

Standard Packaging is Bulk Pack:

Devices will be packaged in plastic bags with a pre-determined quantity. Each bag will be labeled with quantity, part number, lot and date code.

